

RAPTOR

INDUSTRIAL LED SPOT LIGHT

FEATURES:

- LED technology
- Universal base included
- Several mounting options
- Robust die-cast aluminum housing
- 3 mm thick safety glass
- High or low voltage options
- Gooseneck or pivoting head models available
- 50,000 hour LED service life
- Withstands temperatures up to 104° F
- ETL/cETL approved

SPECIFICATIONS:

Voltage	22-28 VDC or 100-240 VAC
Lamping	LED
Color Temperature	5000 K
Beam Angles	10° or 30°
Luminaire Material	aluminum
Lens Material	safety glass
Arm Length (arm version)	22-inch gooseneck
Cable/Plug	10' cable w/free stranded wires
Protection Rating	IP67
Certifications	ETL/cETL
Mounting and accessories	See page 67



RAPTOR LED spotlight impresses with its high-powered LED technology, and 50,000 hours of maintenance-free LED service life. The robust aluminum housing with 3 mm solid safety glass cover stands up to even the toughest machine environments. RAPTOR is available in pivoting head and gooseneck arm versions.



DIMENSIONAL DATA

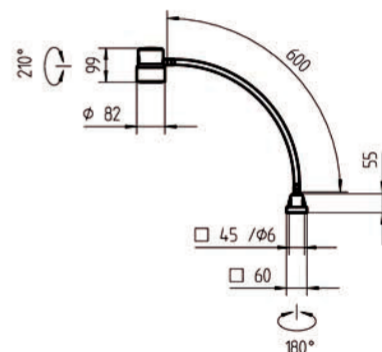
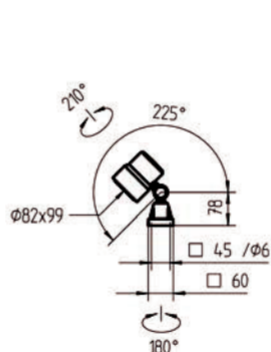

ORDERING INFORMATION

Version	Voltage	Wattage	Beam Angle	Model	Part #
Gooseneck	100-240 VAC; 50/60 Hz	6 W	10°	SLF 500/750	113261000-00641180
Gooseneck	100-240 VAC; 50/60 Hz	6 W	30°	SLF 500/750	113261000-00641183
Gooseneck	22-26 VDC	5 W	10°	SLF 500/750/S	113260000-00641130
Gooseneck	22-26 VDC	5 W	30°	SLF 500/750/S	113260000-00641177
Pivoting Head	22-26 VDC	5 W	10°	SLJ 500/750/S	113259000-00641127
Pivoting Head	22-26 VDC	5 W	30°	SLJ 500/750/S	113259000-00641174

External Operating Devices	Max. Wattage	Input	Output	Part #
	20 W	100-277 VAC, 50/60 Hz	24 VDC	209585029

Mounting Options	Item	Dimensions	Part #
	Table Clamp	0" - 2.75" span	190007019-00014904
	Table Clamp	2.5" - 5.4" span	109033019-00014950
	Wall Mount	2.4" x 2.8"	300213018-00025178
	Magnetic Base	3.3" diameter	190057019-00015056