

Preparation unit——GA Series

GAC Series F.R.L. combination

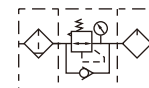

Reflux valve is attached



No reflux valve is attached

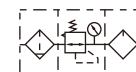

Ordering code

GAC300 □ **10** □ **S** □ **W** **T** **K**

① ② ③ ④ ⑤ ⑥ ⑦ ⑧ ⑨

① Model	② Material of bowl	③ Port size	④ Drain type	⑤ Type code
GAC200:GA200 Series F.R.L unit	Blank: PC N: Nylon C: Metal	06: 1/8" 08: 1/4"	Blank: Semi-auto drain A: Automatic drain	S: Standard L: Lower pressure [Note1]
GAC300:GA300 Series F.R.L unit		08: 1/4" 10: 3/8" 15: 1/2"		
GAC400:GA400 Series F.R.L unit		10: 3/8" 15: 1/2"		
GAC500:GA500 Series F.R.L unit		20: 3/4"		
GAC600:GA600 Series F.R.L unit	C: Metal	20: 3/4" 25: 1"		S: Standard
⑥ Pressure gauge	⑦ Filtering grade	⑧ Thread type	⑨ Reflux valve	
Blank: Circular with clip N: No pressure gauge [Note2]	Blank: 40μm W: 5μm	T: NPT (Scale: bar/psi)	Blank: Without reflux valve K: with reflux valve [Note2]	

[Note1] The work pressure of lower pressure type is 20~58psi(0.15~0.4MPa);

[Note2] Please refer to page 224 for details of sealing plate Installation and reflux valve.

Product feature

1. Oil dripping adopts gap seal structure, which makes the adjustment of oil supply more reliable.
2. Oil feed ring can only make one full turn. The quantity of oil supply, basically taking on linear distribution. The quantity of oil supply can be generally calculated according to the position of graduation ring.
3. Filling of oil while the lubricator is under pressure is made possible.
4. Special drip nozzle structure will produce negative pressure in oil dripping outlet and the mist flow is minimal.
5. Quick and reliable mounting clamps makes it convenient to install and use.
6. The performance of pressure adjustment is reliable with high precision.
7. The efficiency of eliminating moisture and solid grain is high.
8. Two drain types are available: semi-auto drain and automatic drain.
9. Three material of bowl are available: PC, Nylon and metal.

Preparation unit——GA Series

GAC Series F.R.L. combination

Specification

Model	GAC20006	GAC20008	GAC30008	GAC30010	GAC30015	GAC40010	GAC40015	GAC50020	GAC60020	GAC60025	
Fluid	Air										
Port size [Note1]	1/8"	1/4"	1/4"	3/8"	1/2"	3/8"	1/2"	3/4"	3/4"	1"	
Filtering grade	40μm or 5μm										
Pressure range	20~130psi(0.15~0.9MPa)										
Max. pressure	145psi(1.0MPa)										
Proof pressure	215psi(1.5MPa)										
Temperature range	-5~70°C(Unfreeze)										
Capacity of drain bowl	25CC		60CC		100CC		108CC	205CC			
Capacity of oil bowl	36CC		98CC		185CC		225CC	410CC			
Recommended lubricant	ISO VG 32or equivalent										
Weight	750g		1300g		2390g		2460g	4600g			
Constitute	Filter	GAF20006	GAF20008	GAF30008	GAF30010	GAF30015	GAF40010	GAF40015	GAF50020	GAF60020	GAF60025
	Regulator	GAR20006	GAR20008	GAR30008	GAR30010	GAR30015	GAR40010	GAR40015	GAR50020	GAR60020	GAR60025
	Lubricator	GAL20006	GAL20008	GAL30008	GAL30010	GAL30015	GAL40010	GAL40015	GAL50020	GAL60020	GAL60025

[Note1] NPT thread is available.

Inner structure

GAC200

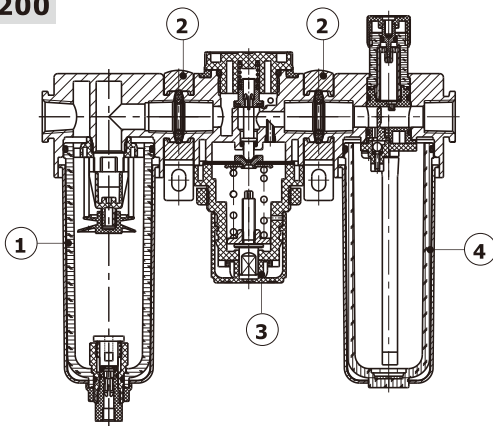

GAC600

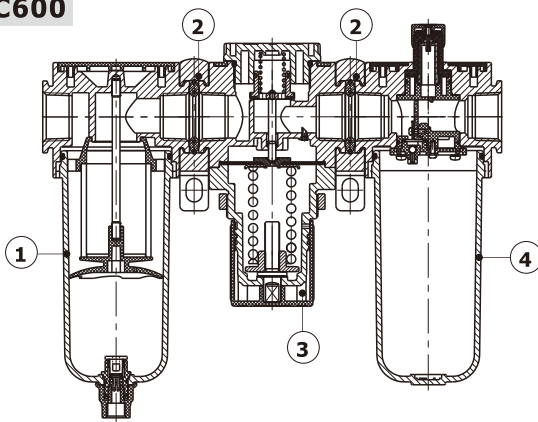

No.	Item	No.	Item
1	GA series filter	3	GA series regulator
2	Bracket	4	GA series lubricator

Pressure chart

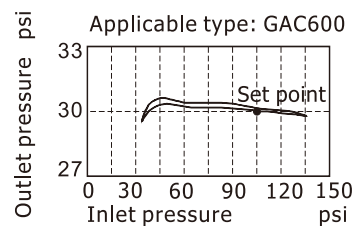
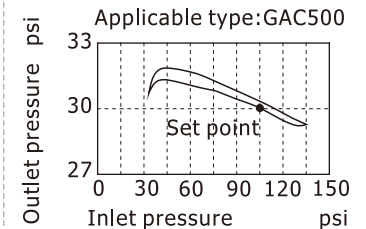
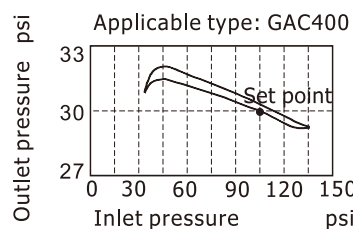
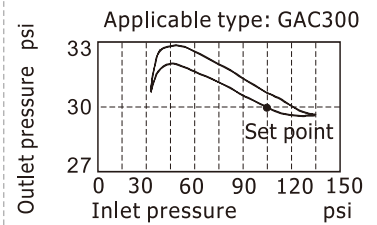
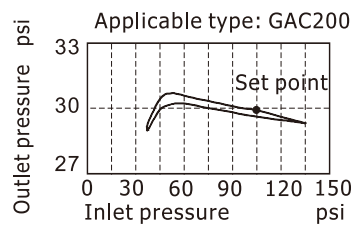

GAC Series F.R.L. combination

Flow chart

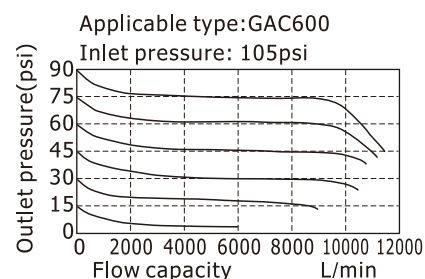
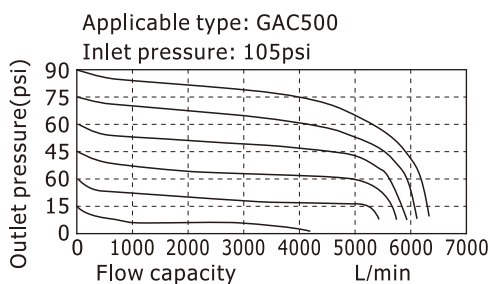
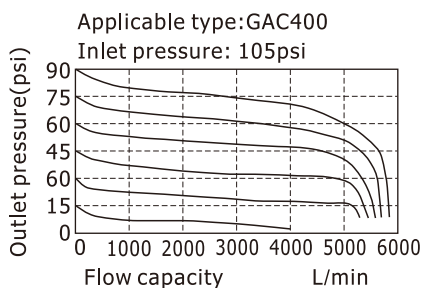
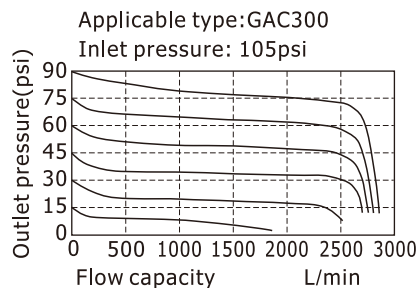
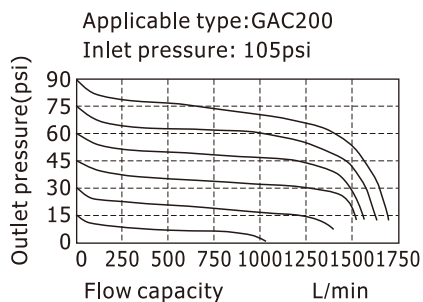

Dimensions

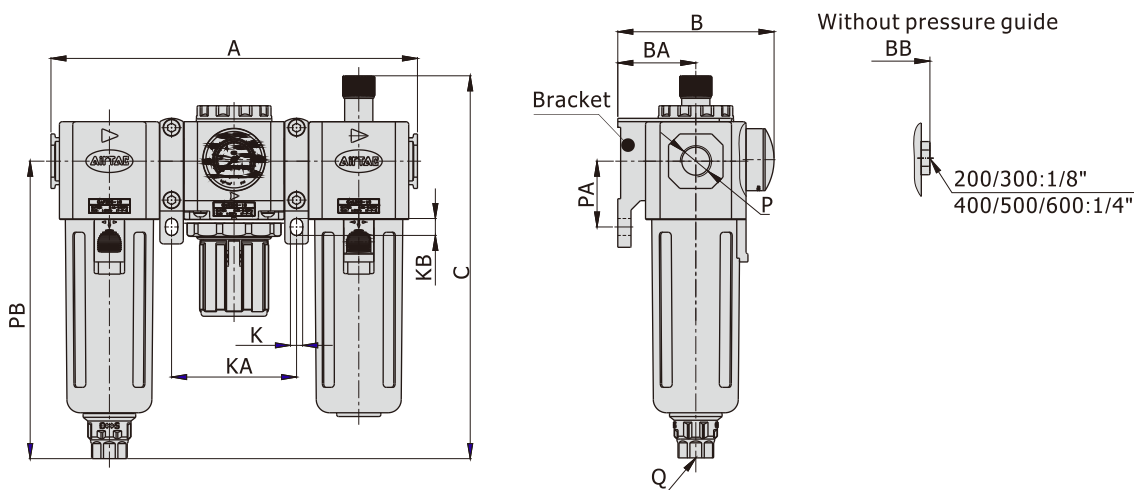

[Unit: mm]

Model/Item	A	B	BA	BB	C	K	KA	KB	P	PA	PB	Q
GAC200-06	163.5	69	30	55.5	160	5.5	55.5	8.5	1/8"	25	120	M5X0.8
GAC200-08	163.5	69	30	55.5	160	5.5	55.5	8.5	1/4"	25	120	M5X0.8
GAC300-08	195	83	41.5	71.5	203.5	6.5	66.5	9	1/4"	35	158	G1/4
GAC300-10	195	83	41.5	71.5	203.5	6.5	66.5	9	3/8"	35	158	G1/4
GAC300-15	195	83	41.5	71.5	203.5	6.5	66.5	9	1/2"	35	158	G1/4
GAC400-10	248	99	50	88	227	8.6	84	12	3/8"	40	177.5	G1/4
GAC400-15	248	99	50	88	227	8.6	84	12	1/2"	40	177.5	G1/4
GAC500-20	254	100	50	89	241	8.6	86	12	3/4"	40	191.5	G1/4
GAC600-20	312	128	70	117	267.5	11	106	16	3/4"	50	205	G1/4
GAC600-25	312	128	70	117	267.5	11	106	16	1"	50	205	G1/4